

Service Rules & Important Information

04/2010

MPW Digital TV is a product of Muscatine Power and Water. Please call Muscatine Power and Water with all of your MPW Digital TV related concerns. We can provide you with technical assistance and help you with questions about programming, billing, subscribing to services, and upgrading or downgrading services.

Address

Muscatine Power and Water
3205 Cedar Street
Muscatine, IA 52761

Hours

Monday through Friday
8 a.m. - 5 p.m.

Phone Number

(563) 263-2631

Website

www.mpw.org

1. BACKGROUND

Muscatine Power and Water is dedicated to providing quality communications services to its customers and to assuring that any problems are quickly resolved to the customers' satisfaction. These customer service procedures, in addition to many other issues, are covered in material generally provided to you at the time of installation and annually thereafter once you become a customer.

This notice summarizes some of the procedures that you need to know to help us answer questions and resolve complaints you may have about billing for the services you receive, the quality of the television signals or other services we provide.

For those of our customers receiving service through commercial accounts, bulk-rate arrangements with multiple-dwelling owners, or similar arrangements, some of the policies, procedures and services herein may not apply. Please refer to the terms and conditions of documents reflecting such separate arrangements. Where such documents are inconsistent with the policies, procedures and information relating to service set forth herein the terms and conditions of such separate arrangements shall apply.

2. DEFINITIONS

Applicant means a person, partnership, association, firm, public or private corporation, governmental agency or legal entity applying to Muscatine Power and Water for services provided for in these service rules.

Complaint means a statement or question by anyone, whether a Utility customer or not, alleging a wrong, grievance, injury, dissatisfaction, illegal action or procedure, dangerous condition or action, or Utility obligation. Complaints are requested to be submitted in writing.

Contract means any claim, account or demand against, or agreement with, the Utility, express or implied.

Customer means any person, firm, association or corporation, any agency of the federal, state or local government or legal entity responsible by law for payment for the communications services from the Utility. In the case of a residence, customer also means other adult persons occupying the residence.

Delinquent or delinquency means an account for which a services bill or services payment agreement has not been paid in full on or before the last date for timely payment.

Equipment means one or more of the following: digital consumer terminal, digital box, digital adapter converter-descrambler, remote-control unit, security device, addressable control module, A/B switch, coaxial cable ("cable") that is not inside wiring, parental lockout device, demarcation box, or any other device installed in or around your home, or provided by us, necessary or convenient for you to receive communications services from us. Inside wiring is not equipment.

Governing Body means the Board of Water, Electric and Communications Trustees.

Home means the place you live, including a single-family home, apartment, other residence or any other type of dwelling unit where your communications services are installed.

Hourly service charge means the hourly charge you pay us for certain services. It is designed to recover the costs of servicing, installing and maintaining customer equipment.

Installed means either installed or activated.

Inside wire or inside wiring means the cable that runs inside your home to a point twelve (12) inches outside of your home and includes any extra outlets, splitters, connections, fittings or wall plates attached to it.

Premises means a tract of land, building, part of a building or facility to which communications services are provided.

Service means the cable TV programming or any other service that we provide to you.

Service rules means these rules as adopted by the Governing Body.

Timely payment is a payment on a customer's account made on or before the date shown on a current bill for services, or on a form that records an agreement between the customer and the Utility for a series of partial payments to settle a delinquent account.

Utility, MP&W we, us, or our means Muscatine Power and Water.

You or your means the customer identified on the work order that was signed to begin your communications services.

3. MUSCATINE POWER AND WATER CHANGES IN SERVICES AND CHARGES

Subject to applicable law, we have the right to change our communications service and equipment, as well as our prices or fees, at any time. We also may rearrange, delete, add to or otherwise change the service provided on our Basic Service or other levels of cable TV service. If the change to our cable TV service affects you, we will provide you notice of the change and its effective date. The notice will be provided on your monthly bill, as a bill insert or by other permitted communication. If you find the change unacceptable, you have the right to cancel your cable TV service. However, if you continue to receive cable TV service after the effective date of the change, we will consider this your acceptance of the change.

To the extent required by law, after notice to you of a retiering of our cable TV services or cable TV rate increase, you may obtain changes in cable TV service tiers at no additional charge. Otherwise, changes by you of any communications services you receive may result in upgrade, downgrade or change of service charges. Please refer to the Services and Rates we have supplied to you for details or call our office at (563) 263-2631 if you have questions.

You may obtain information about the current fees and prices for any of our services by calling our office at (563) 263-2631 or by visiting www.mpw.org. A list of charges also is provided to our customers annually in a mailing or bill stuffer.

4. LIMITED 30-DAY WARRANTY AND LIMITATION OF LIABILITY

Except as explicitly set forth in the terms and conditions of specific services we provide to you, we warrant for a period of thirty (30) days from the date of our installation or repair that our service and the equipment we have installed or repaired will meet accepted industry standards and be free from defects in materials or workmanship. If you report any failure to conform to this warranty to us within that 30-day period, we will reperform the nonconforming services and repair or replace the nonconforming equipment. Such reperformance of work or repair or replacement of nonconforming equipment shall constitute our entire liability and your sole remedy under this warranty, whether claims or remedies are sought in contract or tort (including, without limitation, negligence, strict liability, or otherwise).

In no event shall our employees or agents have any liability for special, indirect, incidental or consequential damages resulting from our provision or failure to provide any equipment or services to you, or from any fault, failure deficiency, or defect in service, labor, materials, work or equipment furnished to you.

The foregoing warranties are exclusive and in lieu of all other warranties, whether written or implied, in fact or in law. We, to the extent permitted by applicable law, disclaim any and all warranties of merchantability or fitness for a particular purpose.

Except as expressly required by law, we will not be liable for any delay or failure to perform our obligations, including interruptions in service, if such delay or nonperformance arises in connection with any acts of God, fires, earthquakes, floods, strikes or other labor disputes, unusually severe weather, acts of any government body or any other cause beyond our reasonable control. This warranty gives you specific legal rights, and you also may have other rights under Iowa law or city ordinances.

5. APPLICABLE LAW

These policies and practices, including all matters relating to their validity, construction, performance, and enforcement are governed by applicable federal law, the rules and regulations of the Federal Communications Commission (FCC), and applicable laws, regulations or applicable ordinances for Muscatine, Iowa. These policies and practices are subject to amendment, modification or termination if required by such regulations or law. If any provision in these policies and practices is declared to be illegal or in conflict with any law or regulation, that provision may be deleted or modified, without affecting the validity of the other policies and practices.

6. NOTICE

If we send you notice, it will be considered given when deposited in the U.S. Mail, addressed to you at your last-known address or hand delivered to you or to your home. We may provide electronic or telephone notice to you, which shall be deemed given when left with you. If you give notice to us, it will be deemed given when received by us.

7. CHANGES TO POLICIES AND PRACTICES

We will notify you of changes to these policies and practices. Any changes proposed by you will only be effective when accepted in writing by an authorized representative of the Utility.

8. EQUIPMENT

Except for the inside wiring, which we consider your property regardless of who installed it, the equipment installed by us belongs to us unless you have purchased the equipment from us. We may at our discretion, supply new or reconditioned equipment to you. Our equipment can only be used in your home. If you cancel your communications service, you are responsible for returning any equipment. The equipment must be returned to us or one of our representatives in working order, with normal wear and tear expected, or you will be charged the retail price for a new replacement for each piece of equipment not returned.

You are responsible for preventing the loss of, or damages to, our equipment within your home. We suggest that your homeowners, renters or other insurance cover the equipment in your possession. You will be directly responsible for repair, replacement and other costs, damages, fees and charges if you do not return to us equipment in an undamaged condition.

You may not tamper with or attempt to repair any equipment supplied by Muscatine Power and Water. We will repair or replace, without charge, any equipment or installation that fails due to reason other than tampering, fire, improper use or failure caused by your own equipment. All repairs and replacements will be billed to you at the following rates:

- Unreturned/Damaged Advanced Digital Box - \$700.00
- Unreturned/Damaged Digital Box - \$300.00
- Unreturned/Damaged Digital Adapter - \$125.00
- Unreturned/Damaged CableCARD - \$150.00
- Replace Damaged/Lost Remote Control - \$10.00
- Digital Equipment Collection Fee - \$25.00
- Unreturned/Damaged Digital Adapter IR - \$5.00

We do not service personal computers, television receivers or any other computer-related or television-related equipment (such as DVD player/VCRs, home antennas or other cable-compatible equipment) not owned by us, even if it is attached to the cable or to our equipment.

None of our equipment, nor any of our cable placed outside your home or property in connection with the installation of the equipment and service shall be deemed fixtures, or in any way part of your real property, unless you purchase our cable to the extent permitted by law when service ends. We may remove

our equipment, at our option, at any time during or following the termination of your service due to nonpayment for service, and you agree to allow us access to your home for such purposes.

We consider inside wiring to be your property, regardless of who may have installed it. You will continue to be responsible for the repair and maintenance of the inside wiring. You may install inside wiring such as additional cable wiring and outlets. Regardless of who does the work, the internal wiring within your home must not interfere with the normal operations of our communications system. Inside wiring maintenance may not be your responsibility if you rent your home. Contact your landlord or building manager to determine responsibility.

9. ACCESS TO CUSTOMERS' HOMES

You authorize us or our designees to enter into your home, in your or your representative's presence, or upon your property during normal business hours or by appointment to install, inspect, maintain, replace, remove or otherwise deal with the equipment supplied by us and service. This authorization includes allowing us or such designee to be on your property outside your home at reasonable times even if you are not at home. You authorize us or our designee to make connections and perform other tasks that are necessary or desirable to enable us to provide service to you or others, including connecting and making necessary attachments to your inside wiring. If you are not the owner of your home, you agree to supply us or our designee, if we ask, with the owner's name and address, proof that you may give us access on the owner's behalf and, if needed, consent from the owner of the home.

10. MOVING

If you intend to move, call us prior to the move so we may disconnect service and you can return our equipment. We will be happy to provide communications services to the new occupants of your home and to provide you with continuing communications services in your new home if it is within our service area.

11. INSTALLATION

Installers bring the cable to the point in your home nearest our facilities and along the easiest route. The cable will be grounded. Standard connections provide visible wiring and include a loop-through hookup to your DVD player/ VCR. Concealed wiring and other custom installation services are available at additional cost. We do not repair holes in floors, ceiling and walls upon disconnection of the communications services. Someone over 18 years of age or the head of household must be home during the installation of your MPW Digital TV service. This will ensure a thorough and complete installation and will allow you to become more familiar with your cable service and equipment.

12. PARENTAL LOCKOUT

Your digital cable TV box contains a device that enables you to prevent viewing of specific cable TV channels, specific cable TV programming or cable TV movies with certain ratings. This feature is included without charge; instructions are contained in your digital box user manual. Parental controls are not available with a digital adapter.

13. BASIC SERVICE REQUIRED

Cable television customers are required to subscribe to at least the Basic Service of cable TV service in order to subscribe to any other cable TV service tiers.

14. PRIVATE VIEWING OF UNAUTHORIZED SERVICE AND USE OF EQUIPMENT

We provide service to you for your private home use and enjoyment. You agree that the services provided over the communications system will not be viewed in areas open to the public. The services may not be rebroadcast, transmitted or performed, nor may admission be charged for its viewing without first obtaining written consent, in advance from our supplier(s) and us. This consent may be withheld at the sole discretion of us or our suppliers.

Muscatine Power and Water may not have the right to distribute Pay-Per-View programming to commercial establishments. You may not order or request Pay-Per-View programming for receipt, exhibition or taping in a commercial establishment. You may neither exhibit nor assist in the exhibition of Pay-Per-View programming in a commercial establishment unless explicitly authorized to do so, in advance, by our program provider and us. You may not move your equipment to another location or use it at any time at an address other than your home or location where we installed service without our prior written authorization. If you fail to abide by these restrictions, you will be held liable for any claims made against you or MPW Digital TV on account of any unauthorized commercial exhibition.

You agree not to attach any unauthorized device to our equipment. If you make any unauthorized connection or modification to the equipment or any other part of the communications system, you will be in breach of these policies and practices, and we may terminate your service. Much of the equipment and many of the devices necessary to receive our services are available both from others and us. If you purchase or lease such equipment from us, you are responsible for assuring that the equipment does not interfere with the normal operations of our communications system and other communications systems and devices. For example, you agree not to install anything, to intercept or receive, or to assist in intercepting or receiving, or which is capable of intercepting or receiving, any service offered over our cable system, unless specifically authorized to do so by us. You are responsible to pay for all services received or otherwise provided to your household. You also agree that you will not attach anything to the inside wiring or equipment, which, singly or together, results in a degradation of our communications system's signal speed, quality or strength.

You may not attach any device or equipment to your inside wiring in a way that impairs the integrity of our communications system, such as creating signal leakage, which may cause a violation of government regulations, or attaching devices or equipment, which alone or together, results in a degradation of signal quality or speed. Further, services or signals provided by us that are carried on or transmitted through the inside wiring or equipment provided by us may not be commingled with signals or services provided by others.

We can recover damages from you for tampering with any of the equipment or any other part of our communications system, or for receiving unauthorized service.

You must return any equipment we supply to you that is owned by others or us when you are no longer a customer. In some cases, you may also choose to buy a equipment from an independent store. Please remember, however, that equipment must meet our specifications. Equipment with descrambling capabilities should only be obtained from us. In fact, should you see advertisements for cable equipment that have descramblers in them (so-called "pirate boxes" or "black boxes") you should understand that these devices might be illegal to sell or use, unless authorized by us. Because of the need to protect our scrambled services, we will not authorize the use of any equipment/descramblers not provided by us. People who use illegal equipment/descramblers may be stealing cable service. This practice may unfairly result in increased prices to our honest customers.

15. APPLICATION FOR SERVICE

Customers may obtain service from the Utility by calling (563) 263-2631 or visiting www.mpw.org. The application form shall include: the customer's name, billing address, service address, telephone number(s), social security number and may include other information as necessary. As soon as practical after the approval of an application, the Utility shall supply service to the applicant in accordance with these service rules and at a rate established by the Utility for the applicant's appropriate class of service.

16. DEPOSITS

A deposit intended to guarantee partial payment of bills for service and equipment might be required prior to approval for communications services. A person other than the customer may pay the deposit. In any case where a deposit has been refunded or is found to be inadequate, a new or additional deposit may be required upon twelve (12) days written notice of the need for such a requirement. A new or additional deposit may be required of a current customer whose initial deposit has been refunded or is found to be inadequate. The new or additional deposit shall ensure a total deposit equal to the two (2) highest monthly billings for service during the previous twelve- (12)-month period and shall apply to customers who make two (2) late payments in a twelve- (12)-month period (not including one automatic forgiveness of late payment). In addition, the new or additional deposit will include the cost of replacement of any communications equipment in use by the customer.

17. BILLING INFORMATION

Your monthly statement provides a listing of your charges, payments and credits, as well as special messages regarding service or rate changes. Please take the time to read the monthly messages and to review your statement carefully to make sure your name and address are correct. You generally will be billed at the same time each month.

We provide service to you on a monthly basis that coincides with your current utility billing cycle. All communications charges will appear on your regular monthly utility statement. If there are any billing errors or other requests for credit, you must bring those to our attention within twenty (20) days of receiving the bill. Specific billing information only will be made available to the customer or others as designated by the customer.

The Utility, at its option, shall either place the following information on the billing form, or shall advise the customer on the billing form, that the following information can be obtained by contacting the Utility's business office:

- The charges for any communications services incurred at the beginning and end of the billing period.
- The date communications services were incurred.
- The account balance brought forward and amount of each charge for Utility communications service, sales tax, city fees, franchise fees, other charges, late payment charge and total amount currently due.
- The last day for timely payment shall be clearly shown and shall not be less than twenty (20) days after the bill is rendered.

The invoice you receive will show the total amount due and the payment due date. You agree to pay us monthly by the payment due date for that service and for any other charges due us, including any fees due to late payments or any returned check fees. The Utility also may assess other fees or charges.

You agree to pay all taxes, city fees, franchise fees and other charges that are now, or may in the future, be assessed on the services you receive from us.

If your communications service is disconnected because you have not paid your bill by the due date, we shall require you to pay all past-due charges, a reconnection fee of not less than \$25, and a minimum of one (1) month's deposit before we reconnect your service. If you do not reconnect, any rental equipment must be returned to Muscatine Power and Water. Muscatine Power and Water may require customers who have past-due accounts to bring their accounts up to date before ordering communications service. If past due accounts are not paid, service may be refused. If you change the services you receive, we may charge you a change-of-service fee, such as upgrade or downgrade charges. If you have any questions, please contact Muscatine Power and Water at (563) 263-2631 or ask the customer service representative you talk to when requesting a change in service.

We urge that you call Muscatine Power and Water at (563) 263-2631 any time you have questions or concerns about your service, DVD player/VCR hookup questions or problems, or any other aspect of the communications service.

18. WHERE PAYABLE

Bills may be paid online at <https://www.mpw.org/onlinepay>, by mail, by direct payment at the Utility business office, or by direct deposit through a bank or credit union.

19. LATE PAYMENT PENALTY

A bill shall be due and payable when rendered and shall be considered delinquent after twenty (20) days from the time it is rendered. A bill shall be considered rendered by the Utility when deposited in the U.S. Mail with postage prepaid or when delivered by the Utility to the last known address of the party responsible for payment. Bill payments received by the Utility after the due date shall be for the amount stated on the bill that shall include a late payment penalty of 1.5 percent per month of the past due amount. Failure to receive a properly rendered bill shall not entitle the customer to relief from penalties for late payment.

Each account shall be granted one (1) complete forgiveness of a late payment penalty in each calendar year. The customer shall be informed of the use of the automatic forgiveness by posting to the next bill.

No collection fee will be levied in addition to this late payment charge. This does not prohibit cost justified charges for disconnection and reconnection of service, or court costs and other legal expenses associated with our attempts to recover payment on delinquent accounts.

20. PARTIAL PAYMENTS

Payments on bills including other services will be applied to Communications services first and then applied to the applicable other services unless specifically requested to be applied differently.

21. RETURNED CHECKS

A service charge of \$30.00 shall be assessed to any customer whose check is returned or not honored by the bank from which it is drawn. The service charge shall be in addition to the late payment penalty if the check is not made good prior to the delinquent date of the bill. If two (2) or more checks are dishonored within a six- (6)-month period, the Utility may require future payments by cash, cashier's check, or money order.

22. REASONABLE AGREEMENT TO PAY

A residential customer disconnected or about to be disconnected who is unable to pay a delinquent bill in full may be offered an opportunity to enter into a reasonable agreement to pay that bill unless the customer is in default upon an agreement. The agreement shall require the customer to bring the account to a current status by paying specific amounts at scheduled times.

A signed copy of the agreement shall be provided to the customer.

Default of the agreement by the customer renders the customer subject to disconnection in accordance with proper procedures except that the twelve- (12)-day notice (as described in Section 26) provision does not apply.

23. TERMINATION OF SERVICE

Unless you have otherwise agreed (such as where you have agreed in advance to receive service over a specified period of time), you have the right to cancel your service for any reason at any time by giving us notice. We will refund any balance due to you within twenty (20) days or upon the return of any of our equipment, if later. Subject to applicable law, if you fail to pay your bill when it is due, we have the right to terminate your service.

You may not assign or transfer the service without our written consent. The individual policies and practices in this document will continue and apply to your rights and those of the Utility after the end of your service.

24. CREDITS

Credits for service will be issued no later than the customer's next billing cycle following the determination that a credit is warranted.

25. VOLUNTARY DISCONNECTIONS, DENIALS AND RECONNECTIONS

Temporary Disconnections and Reconnections - (Voluntary)

The Utility may, upon reasonable notice by a customer, make temporary disconnections for the customer's convenience. The customer will be required to pay a fee for disconnection and for reconnection. The customer shall pay for disconnections and reconnections at the applicable rates for labor, equipment and material(s). All amounts, due or past due, that the customer owes the Utility shall have been paid in full.

Permanent Disconnections - (Voluntary)

A customer requesting permanent disconnection shall provide a minimum notice time to the Utility of one (1) business day. With proper notification, no charges shall be made for permanent disconnections.

26. INVOLUNTARY DISCONNECTIONS, DENIALS AND RECONNECTIONS

Just Cause for Discontinuance or Denial - (Involuntary)

The Utility reserves the right to refuse or discontinue communications service for any of the reasons listed below, subject to the provisions of this section and other provisions of these service rules. Unless otherwise stated, the customer shall be given written notice at least twelve (12) days prior to discontinuance of service, and in the event the customer has failed to comply with a rule of the Utility, he or she shall be given at least twelve (12) days from written notification to comply with the rules. Except for reasons given in the first four reasons listed below, or disconnection at the customer's request, no service shall be discontinued unless the Utility is prepared to reconnect the service within twenty-four (24) hours. A reconnection fee shall be charged when the discontinuance results from an act or omission on the part of the customer. Reasons for refusal or discontinuance of service are:

- Without notice in the event of a condition determined by the Utility to be hazardous.
- Without notice in the event of customer use of equipment in such a manner as to adversely affect the Utility's equipment or the Utility's service to others.
- Without notice in the event of tampering with the equipment furnished and owned by the Utility.
- Without notice in the event of unauthorized use or resale of the Utility's service.
- For violation of or noncompliance with the Utility's service rules and other user agreements.
- For failure of the customer or prospective customer to fulfill his contractual obligations for service or facilities.
- For failure of the customer or prospective customer to permit the Utility reasonable access to its equipment.
- For failure of the customer or prospective customer to furnish service equipment, permits, certifications or rights-of-way specified by the Utility as a condition of receiving service.

Written Notice - Disconnection or Denial for Just Cause - (Involuntary)

Any written notice mailed to a customer pursuant to Muscatine Power and Water service rules will set forth the reason or reasons for the pending disconnection or denial, and the final date by which the account is to be settled or specific action taken. If more than one reason is specified, the days of notice for the causes shall be concurrent. The notice shall be considered rendered to the customer when deposited in the U.S. Mail with postage prepaid. If delivery is by other than U.S. Mail, the notice shall be considered rendered when delivered to the last known address of the person responsible for payment of the service. The final date shall not be less than twelve (12) days after notice has been rendered.

Disconnection and Reconnection Fee (Involuntary - Other Than Nonpayment)

For any disconnection or reconnection from a disconnection or denial of service pursuant to these service rules, the customer shall pay for disconnections and reconnections at the applicable rates for labor, equipment and material(s).

27. NONPAYMENT OF BILL OR DEPOSIT - DISCONTINUANCE OR DENIAL

The Utility reserves the authority to discontinue or deny service for nonpayment of the bill or deposit, subject to the provisions of these service rules.

Reconnection Fee for Nonpayment

For any reconnection from a disconnection or denial of service pursuant to these service rules, there shall be a reconnection service charge of not less than \$25.00 during normal working hours. Before service is restored, all outstanding communications bills shall be paid.

28. PROCEDURES FOR DISCONTINUANCE FOR NONPAYMENT

Service shall not be discontinued for nonpayment of bill or deposit unless the Utility has:

Reasonable Attempt

Made a reasonable attempt to collect.

Written Notice

Given written notice to the customer (and, where applicable, the person or agency designated by the customer to receive such notice) that service will be discontinued if the account is not settled within twelve (12) calendar days from the date of notice.

29. SERVICE CALLS

The Utility will make every possible effort to provide continuity of communications services, but the Utility does not guarantee continuity of service and shall not be held liable for interruption of communications service.

Charged Service Calls

Customers may be billed for the cost of services not the responsibility of the Utility as follows:

Residential Customers

For the relocation of Utility facilities at the customer's request, an advance payment equal to the total estimated cost of the relocation shall be made. The customer shall be responsible for the actual cost of the relocation.

Commercial Customers

For a requested relocation of facilities belonging to the customer or Utility, a payment equal to the total estimated cost shall be required in advance of any construction. The customer shall be responsible for the actual cost of the relocation.

Non-charged Service Calls – Underground Facilities Locating

The customer shall not be billed for service calls or equipment that are the responsibility of the Utility. The Utility will locate underground service facilities owned by the Utility without charge. The request should be made at least two (2) business days in advance and can be done so by calling Iowa One Call at 1-800-292-8989. Every effort to correctly locate the underground facilities will be made by the Utility, but the Utility cannot guarantee its location nor be held liable.

30. CUSTOMER COMMUNICATIONS

Utility Customer Representative

A Utility representative charged with customer communication must give his or her name to the customer, whether communication is in person or by telephone. The representative must have immediate access to current detailed information concerning the customer's account and previous contact with the Utility and shall be properly qualified and instructed in the screening and prompt handling of complaints.

When you call about a service problem during normal business hours, a Customer Service Representative (CSR) will attempt to determine the nature of the problem. If possible, the CSR will help you resolve the problem over the telephone. If the problem cannot be resolved during the call, the CSR will schedule a Service Technician to visit your home, usually within twenty-four (24) hours of the time of the call. If our workload permits, the Service Technician will be dispatched the same day.

We maintain a local telephone number that will be available to you twenty-four (24) hours a day, seven (7) days a week, every day of the year. If you call about a service problem outside regular business hours, the call may be answered by an answering machine or other Utility staff who will have to take a message. In your message, provide your name, number, and describe the nature of the problem. Please leave both your home and work numbers. We will call you during normal business hours the next working day to resolve the matter. When possible, a Service Technician will be dispatched promptly to fix the problem.

Emergencies, such as fallen utility poles, violent storms or very cold weather, may interfere with the quality of service. We are committed to have our crews promptly correct outages or other service-related problems occurring as a result of an emergency situation. We pledge a prompt response at any time if a large area of the system is experiencing technical difficulties.

Our CSRs and Service Technicians are well trained and have authority to attempt to resolve a customer's problem, including replacement of any nonoperating equipment, in order to provide quality service.

We offer an "appointment window" for installation, service calls, or other installation activities that are either a specific time, or at a maximum, a four-(4)-hour time block during normal business hours.

We commit to a policy to not cancel our appointment with you after the close of business in the business day prior to a scheduled appointment. If we are running late for an appointment, we will attempt to contact you and will, as necessary, attempt to reschedule to a time that is convenient for you.

Telephone Procedure

Telephone number (563) 263-2631 is monitored continuously for the handling of problems or complaints of an emergency nature.

Complaint Procedure

Complaints concerning the charges, practices, quality of cable TV signals, facilities or service of the Utility shall be investigated promptly and

thoroughly. The Utility shall keep records of written complaints sufficient to enable review and analysis of its procedures and actions. Customers shall be asked to submit complaints in writing.

The complaint shall include the following information:

- Name(s) of complainant.
- Address(es) of complainant.
- Telephone number(s) of complainant.
- Nature of the complaint.
- Relief sought.

Initial contact by a customer regarding a complaint shall be made with a CSR of the Utility. The complaint may be pursued with the appropriate Supervisor or Manager, the appropriate Director and the General Manager, in that order, if the customer is not satisfied with the handling of the complaint.

A written complaint may be filed with the Chairperson of the Governing Body if the customer is not satisfied with the General Manager's handling of the complaint. If the Chairperson believes the customer's complaint warrants further attention, the Chairperson may place the complaint on the agenda of the next regularly scheduled Board meeting for ultimate resolution of the complaint by the Governing Body.

A customer who is unable to travel need not appear before any Utility official described above in person to explain the nature of their complaint. They may do so by telephone or in some other mutually agreeable fashion.

Complaints involving policies or actions of the Utility that are regulated by the FCC may also be filed with the FCC in accordance with applicable regulations. Fruitland customers may contact the City of Fruitland at Fruitland City Hall, 104 Sand Run Road, PO Box 95, Fruitland, IA 52749, or (563) 264-1748. The community ID for the County of Muscatine (unincorporated) is IA0935, the County of Muscatine (incorporated city) is IA0936 and Fruitland is IA0938.

31. PERSONAL INFORMATION DISCLOSURE

As a communications services subscriber, there are some forms of personal information that will be collected in the connection and the operation of our communications service. This information includes: your name, both physical and mailing address, billing status, loaned or rented equipment, service record, social security number and/or driver's license number, employer and any complaints. This information may not be disclosed for any purpose without your consent except as described in this statement. Collected information, as well as delivery or maintenance of services and equipment, billing, accounts, collection, advertising or detection of unauthorized reception of communications services, is necessary to provide our communications service or other services to you and to conduct legitimate business activities related to our communications system.

In addition to these activities, this information may be disclosed on a day-to-day basis to employees or agents of our system, including, but not limited to sales or marketing personnel, billing or collection services, auditors, accountants, attorneys, lenders, programmers and regulatory agencies. Your name and address also may be disclosed to program guide suppliers or other non-cable services so that you may receive programming guides or other services.

This disclosure will not indicate the extent or type of any use you make over the system. If you wish for us to limit or prohibit this disclosure, you must notify us in writing that you do not want the information released. Information personally identifying you may also be disclosed after notice to you if required by a court order authorizing such disclosure. Information that personally identifies you shall be maintained by our office for as long as necessary for the purpose for which it was collected.

You may have access to review and correct this information in our Customer Services Department at any time during normal business hours. Please contact us in advance if you wish to review your records. If you are offended by an act of a communications operator in violation of these limitations on the collection and disclosure of personally identifiable information, you may bring a civil action suit for damages in the United States District Court to enforce these limitations. This remedy is in addition to any other lawful remedy available to you.

32. HOW TO USE YOUR CABLE SERVICE

There are few better values today than MPW Digital TV television. This information is provided to you to enable you to be more knowledgeable about your service and to answer any questions you may have about that service.

Viewing Tips

Here is a sample of the quality and choices that may be available to you.

Entertainment

Current, classic, and made-for-cable movies, comedy, drama, TV series, programming from around the globe and more.

Sports

Sports from around the globe. Collegiate and professional football, and auto racing and more.

basketball, baseball, tennis, soccer, track, golf, hockey

Music

Rock, Rhythm and Blues, Country, Jazz, Urban Contemporary, Spanish, performances of your favorite performers.

Christian, and more, plus an endless variety of video

News and Information

24-hour coverage of late-breaking national and world events. Congressional proceedings and talk shows, timely financial news from national and programming.

international markets, Local and national weather, and local

Education

Science, the environment and the future.

33. HOW CABLE TELEVISION WORKS

Cable television brings you more channels and generally better reception than off-air reception of broadcast television since TV signals travel to your home by cable rather than through the air. Television stations are brought into your home through miles of high-tech cable. Your television reception is uninterrupted by trees, buildings and other surface obstacles.

In addition to certain local TV stations, communications satellites let you receive many additional channels through cable TV. A large selection of viewing choices is available through MPW Digital TV.

1. Individual television programs are produced in many places around the world.
2. Programs are transmitted to communications satellites that orbit the earth. These satellites stay in a fixed position 22,300 miles above the earth, allowing them to transmit to our community.
3. Local satellite dishes receive these signals.
4. The cable television head end, or control center, processes these satellite signals, along with the signals from your local TV stations and other sources, so the signals can be transmitted over our cable system to your home.
5. These quality television programs are brought to your home via hundreds of miles of fiber optic and coaxial cable, either strung on the same utility poles that bring you electric service or buried underground.

34. GENERAL DOs and DON'Ts

We have installed MPW Digital TV in your home in a manner that is consistent with Federal Communications Commission (FCC) rules. Here are a few tips to keep it operating safely and reliably.

1. During severe electrical storms, you should unplug your TV set and cable equipment to avoid damage. MPW Digital TV and set manufacturers are not responsible for damage that occurs due to acts of nature.
2. Remember, your cable equipment operates on 110 volts, so take all the precautions you would for any small appliance, such as checking to see that the cord is not worn or damaged.
3. For your own safety, do not attempt to open or otherwise tamper with your cable equipment.
4. If you have someone other than us install the inside wiring in your home, or if you do it yourself, ensure that it complies with applicable governmental regulations (such as the FCC signal leakage rules) and does not interfere with the normal operations of the cable system and other communications systems (such as radios used by the police and fire departments) and devices.

35. THEFT OF SERVICE

The 1984 Cable Act created both civil and criminal penalties for manufacturers, suppliers and users of unauthorized cable devices. This federal theft-of-service law supplements any existing Iowa laws, and it provides a federal remedy against any person who, without authorization, intercepts or receives any communications service provided over a cable system.

Federal law prohibits the unauthorized interception or receipt of any communications service over a cable system. This would include the theft of audio, video, textual data or other service, including data transmitted to or from a customer over a system that has interactive capability. The law applies to both manufacturers and distributors of equipment, as well as individual subscribers.

The 1984 Cable Act, the 1996 Telecom Act, and other federal laws provide both civil and criminal penalties for the theft of cable services. Under this federal regulation legislation, a cable operator may seek substantial monetary damages for the theft of its cable services. In addition, if the violations are willful and for commercial advantage or private financial gain, the court may award damages of up to \$50,000 in civil cases and a maximum of \$100,000 for certain criminal violations, in addition to a maximum of five years imprisonment for subsequent offenses. Theft of utility services is also a criminal violation under Iowa law.

This legislation was enacted by Congress because it believes that theft of cable service poses a major threat to the economic viability of cable operators and cable programmers. Theft of service creates unfair burdens on cable subscribers who are forced to subsidize the benefits that other individuals are getting by receiving cable service without paying for it.

36. ABOUT YOUR EQUIPMENT

If you have a cable ready TV set, you will not need equipment to receive MPW Digital TV basic service. You'll need equipment if you subscribe to Select Service or above and wish to receive Music Choice, On Demand, and Pay-Per-View services, as well as premium networks. When you use digital equipment, you may not be able to use special features and functions of your TV and DVD player/VCR, including those that allow you to view a program on one channel while simultaneously recording a program on another; record two or more consecutive programs that appear on different channels; and use advanced picture generations and display features such as Picture in Picture, channel review, and functions that necessitate channel selection by the consumer device.

We offer for lease digital equipment and remote controls. Digital boxes that unscramble services also provide our customers with the option to use "parental control" to block out channels they wish not to view.

37. REMOTE CONTROLS

Some digital equipment can be operated by a hand-held remote control device. We provide a remote control with your equipment rental. It is possible that the remote control that came with your TV or DVD player/VCR is capable of controlling our equipment. If that is the case, feel free to use it. The types of digital equipment we use are from Motorola. You may purchase a "universal" remote control capable of working with our equipment at a retail outlet. If you plan to purchase a remote and are uncertain of its compatibility, please contact us.

38. TROUBLESHOOTING MPW DIGITAL TV PROBLEMS

There's a lot that happens to your cable signal before it gets to your TV screen. MPW Digital TV's state-of-the-art fiber-optic communications system gives you the best quality picture and sound available. If you're having a problem with your picture quality, try these simple things before you give us a call:

1. Make sure the equipment and television are plugged into a live electrical outlet.
2. Check to see if the problem is affecting all TV sets in your home that are connected to cable.

3. If you have digital equipment, tune your TV set to channel 3.
4. Switch all cable-ready TV sets to "CATV."
5. Hand tighten all the connections to your TV, equipment, and DVD player/ VCR.
6. Double check that your electric game system, PC or any other equipment connected to your TV is connected properly for viewing cable.
7. Make sure the batteries in your remote control are charged.

39. CABLE AND YOUR DVD PLAYER/VCR

If you are a DVD player/VCR owner, you can use your DVD player/VCR to receive additional enjoyment from your MPW Digital TV service.

We want to help you understand how to make your DVD player/VCR and cable television components compatible. With your cable and DVD player/VCR combination, you can now record your favorite movies and cable programs for later viewing. We want you to have maximum flexibility in watching what you want, when you want.

DVD Player/VCR-Cable Hookup Warnings

1. Additional equipment, such as cable jumpers, signal splitters or A/B switches, may cause picture distortion if they do not meet our system's standards. Please call us at (563) 263-2631 before you purchase additional hookup equipment.
2. We recommend against cutting cable jumpers. An improperly cut cable may cause picture distortion.
3. All cable connections should be hand tightened.

40. INSTALLING YOUR EQUIPMENT AND DVD PLAYER/VCR

With your DVD player/VCR, you can access a whole world of entertainment, record what you wish to see, and watch it at whatever time you find convenient. Installation of your DVD player/VCR can be completed through a variety of different methods depending upon your viewing and recording requirements. The various options available to you for connecting your DVD player/VCR are described on the next few pages.

Diagram One

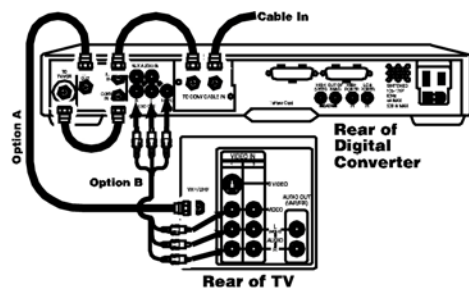

The connections in Diagram One are the most basic, with your digital box connected directly to your TV. These are good options if you don't have a DVD player/VCR. Option A allows you to tune analog channels without turning on your digital box. Option B allows you to receive stereo sound from both the analog and digital channels if you have a TV with stereo capability. Option C uses both connections in Options A and B and gives you both features.

Diagram Two

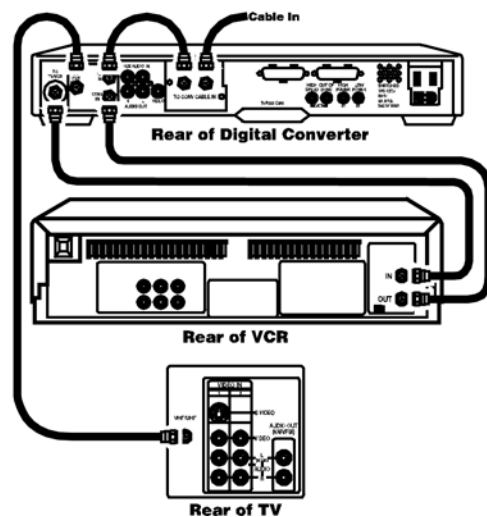

The connection in Diagram Two adds a DVD player/VCR. The DVD player/VCR is connected so you can record the program you are watching. You can play tapes and use the DVD player/VCR to record programs. It also allows you to tune analog channels without turning on your digital box.

Diagram Three

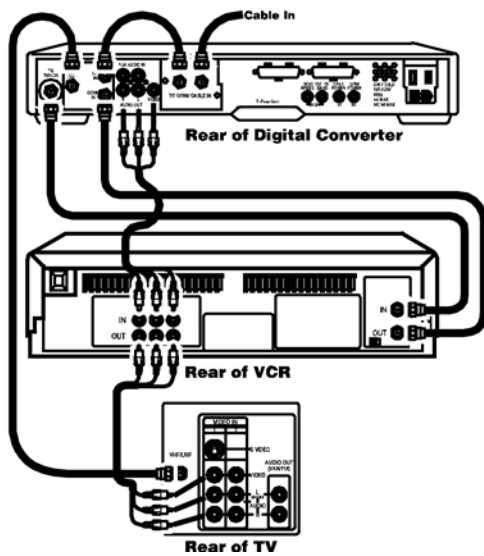

You can use the connections in Diagram Three if you want to record digital channels with stereo sound. It allows you to record the program you are watching, play tapes and use the DVD player/VCR to record programs. You also can tune analog channels without turning on your digital box with this option.

Diagram Four

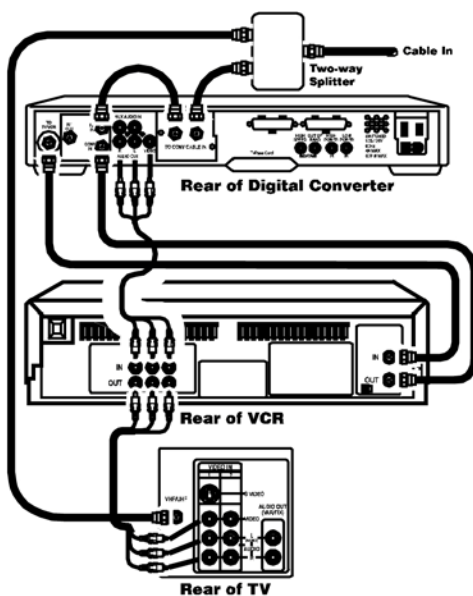

Diagram Four gives you the most options. It allows you to record a digital channel while watching an analog channel, or record an analog channel while watching another analog channel. You can record the program you are watching, play tapes and use the DVD player/VCR to record programs. It also preserves your TV's picture in picture feature. This option requires a two-way splitter between your wall plate and your digital box.

There are many additional ways to connect your digital box to your TV, DVD player/VCR, stereo receiver and home stereo equipment. Please note that the back of your TV and DVD player/VCR may look somewhat different from the diagrams shown above.

41. A BRIEF SYNOPSIS OF MPW DIGITAL TV SERVICES

Basic Service

Basic Service is one of our most viewed levels of service. Basic Service may include off-air broadcast stations and franchise-required public, educational, and government access channels. All such programming is subject to change at any time. MPW Digital TV customers must subscribe to Basic Service in order to subscribe to any tiers of cable service offered.

Select Service

Select Service is the level of service that generally carries all non-premium cable channels, such as The Discovery Channel, Lifetime, ESPN, A&E, USA, TNT, and regional sports services, as well as our Select HD package with monthly rental of an advanced digital box. Our Select Service includes all of the channels

available on our Basic Service as well. Currently, digital equipment is required to receive Select Service, which includes access to Pay-Per-View, premium network multiplex services, and On Demand, among other features.

Preferred Service

Preferred Service includes additional digital channels, including ESPNU, Nick Jr., TeenNick, bio., History International, Military History Channel, ci (Crime & Investigation), RTN (Retro Television Network), and many more. This service requires digital equipment rental.

Premium Services

Premium Services are available to customers who receive Basic Service. Customers need not currently purchase the additional, optional level of service – Select Service – in order to receive premium channels. Premium channels include Home Box Office (HBO), Showtime, Cinemax, The Movie Channel, STARZ, and Encore. There is a separate monthly charge for each premium network a customer receives. This service requires digital equipment rental.

Other Optional Services

In addition to these programming services, we also offer for an additional monthly charge, the rental of advanced digital boxes (which come with basic HD/DVR services) and remotes, a Spanish tier of channels, Pay-Per-View, On Demand and other services.

42. A NOTE ABOUT PROGRAMMING

We receive programming from various non-cable and cable networks. We are not responsible for the content of programs aired by these networks. Programming complaints or questions should be directed to the cable or broadcast networks.

43. EQUIPMENT COMPATIBILITY - "CABLE READY" AND "CABLE COMPATIBLE EQUIPMENT"

One of the reasons you may subscribe to our cable system is that we offer many more channels of programming, in addition to what you may be able to receive off-the-air. Some of you may have TV receivers or DVD player/VCRs that can tune to all non-scrambled channels we provide. Others may have older sets that are unable to tune in all channels available over the cable system.

Even if you have an older TV or DVD player/VCR that was advertised as being "cable ready" or "cable compatible", the equipment may not perform as you expected when connected directly to cable. This is because there previously were no standards applicable to TV set manufacturers governing the reception of cable channels. According to new federal regulations, TVs and DVD players/VCRs sold in the United States as of July 1997 cannot be called "cable ready" or "cable compatible" unless they comply with new technical requirements adopted by the FCC, including the ability to properly tune cable channels.

You may encounter additional problems or interference when your TV set or DVD player/VCR is connected directly to cable. For example, you may encounter co-channel interference or an inability to receive higher number channels. These problems are often solved through the use of digital equipment. Equipment is available through MPW Digital TV for a monthly fee. The equipment will "convert" the cable channels to a designated channel on your TV. Please understand that the process of converting all of our channels to such a channel means that you can only receive one channel on your TV set at a time through the equipment. This means there may be certain features of your TV or DVD player/VCR that depend on channel turning of these devices that you will not be able to use. For example, taping one program while watching another, recording two or more consecutive programs appearing on different channels and the use of picture-in-picture may not be possible without additional equipment.

44. AVAILABILITY OF SPECIAL BY-PASS EQUIPMENT

Some of the channels offered on the cable system also may be scrambled and may be viewed only if digital equipment is used. However, as described above, equipment may limit your ability to use certain advanced features on your TV set or DVD player/VCR. If you use equipment and you have problems using the special features, additional special equipment may be necessary to regain some or all of these features. MPW Digital TV will consult with you in order to determine what specific equipment may be available to solve your particular situation. This may include additional digital equipment, or, if you have a receiver that can tune our cable channels, possibly a switch (or special equipment with a switch) that will enable you to by-pass the equipment and tune all unscrambled channels with your TV or DVD player/VCR. Please contact us regarding your needs, and we will be happy to discuss alternatives with you and give you a schedule of charges.

45. MPW DIGITAL TV RESIDENTIAL MONTHLY PRICES

Basic ⁽¹⁾	\$19.99
Digital Service Packages⁽²⁾	
Select	\$54.49
Preferred	\$60.99
Preferred Xtra	\$65.99
Preferred Plus 1	\$73.99
Preferred Plus 2	\$83.99
Preferred Plus 3	\$90.99
Ultimate	\$97.99
Additional Digital Products & Services⁽²⁾	
HD Plus (2 channels) ⁽³⁾	\$3.49
Spanish (10 channels)	\$7.49
HBO A La Carte (up to 15 channels)	\$15.50
Cinemax A La Carte (up to 13 channels)	\$13.99
Showtime & The Movie Channel	
A La Carte (up to 13 channels)	\$13.99
Starz & Encore A La Carte (up to 23 channels)	\$13.50
Encore (up to 14 channels)	\$6.50
HBO On Demand Subscription ⁽⁴⁾	\$9.99
Starz On Demand Subscription ⁽⁴⁾	\$6.99

WWE 24/7 Subscription ⁽⁴⁾	\$7.99
Disney Family Movies ⁽⁴⁾	\$4.99
On Demand/Pay-Per-View movies/events.....	prices vary
Cable Wire Protection Program.....	\$2.99

Installation and Service Fees

Initial Installation (up to 4 outlets).....	\$40.00
Drop/Bury Installation	\$50.00
Drop/Bury Replacement Due to Damage.....	\$300.00
Additional Outlet Installation.....	\$25.00
VCR, DVD, Surround Sound, A/B Switch Connection (initial trip)	FREE
VCR, DVD, Surround Sound, A/B Switch Connection (subsequent trips)	\$25.00/hr.
Relocate Outlet	\$25.00/outlet
Reconnect Fee	\$25.00
Service Price.....	\$25.00/hr.
RG-6 Coaxial Cable.....	\$.06/ft.
Late Payment Fee	as per policy
Insufficient Funds Fee	\$30.00

Equipment Fees

Digital Adapter with Remote Control	\$1.25/mo
Discounted to 99¢/mo. through 2010	
Standard Digital Box with Remote Control.....	\$4.00 ea/mo.
Advanced DVR/HD Digital Box.....	\$11.99 ea/mo.
with Remote Control (includes our DVR & basic HD programming ⁽¹⁾)	
CableCARD	\$1.00 ea/mo.
Replace Damaged/Lost Remote Control	\$10.00 ea.
House Amplifier	\$35.00 ea.
A/B Switch.....	\$5.00 ea.
Unreturned/Damaged Advanced DVR/HD Digital Box Fee	\$700.00
Unreturned/Damaged Standard Digital Box Fee	\$300.00
Unreturned/Damaged Digital Adapter Fee.....	\$125.00
Unreturned/Damaged CableCARD	\$150.00
Unreturned/Damaged Power Cord.....	\$15.00
Unreturned/Damaged Digital Adapter IR	\$5.00
Digital Equipment Collection Fee	\$25.00

(1) All standard service subscribers must sign up for Basic service to subscribe to any other services.

(2) A Standard or Advanced Digital Box is required for Music Choice, the interactive on-screen guide, On Demand, Pay Per View, the Spanish package of channels, and premium networks. A Digital Adapter or Standard or Advanced Digital Box is required for each television that will receive any other digital channels.

(3) Requires monthly rental of an Advanced DVR/HD Digital Box for each television that will receive HD programming. In order to receive premium network HD programming, you must subscribe to the premium suite associated with the HD premium network.

(4) Must subscribe to any MPW Digital TV digital service. In order to receive HBO On Demand and/or Starz On Demand, you must subscribe to either the HBO and/or Starz premium service.

Other restrictions may apply.

46. MPW DIGITAL TV RESIDENTIAL CHANNEL LINEUP

Basic (30 channels)

1	On Demand*
2	Government Access
3	WGN America
4	WHBF (CBS) Rock Island
5	JTV 5
6	KWQC (NBC) Davenport
7	KLJB (FOX) Davenport
8	WQAD (ABC) Moline
9	MPW Digital TV Public Access
10	Educational Access
11	WBQD (MyNetworkTV) Davenport
12	KIIN Iowa City (PBS)
13	KGCW (CW) Davenport
14	WQPT (PBS) Moline
23	C-SPAN

- 24 C-SPAN2
- 25 The Weather Channel
- 26 HSN
- 27 Commercial Access
- 29 EWTN
- 30 Inspirational Network
- 31 QVC
- 32 TV Guide Network
- 142 RTN*
- 143 IPTV Learns*
- 144 IPTV World*
- 145 WQPT Worldview*
- 146 This TV*
- 156 KWQC Local Radar*
- 158 WQAD Local Radar*

Select (61 channels)*

- 33 ESPN
- 34 ESPN2
- 35 ESPN Classic
- 36 FOX Sports Midwest
- 37 Comcast SportsNet Chicago***
- 38 FOX Sports Espanol
- 39 Golf Channel
- 40 Big Ten Network
- 41 Disney Channel
- 42 Nickelodeon
- 43 ABC Family
- 44 Cartoon Network
- 45 Disney XD
- 46 USA
- 47 A&E
- 48 Lifetime
- 49 Animal Planet
- 50 Discovery Channel
- 51 TLC
- 52 History Channel
- 53 Travel Channel
- 54 Home & Garden TV
- 55 American Movie Classics
- 56 Fox Movie Channel
- 57 TBS
- 58 fx
- 59 TNT
- 60 SyFy
- 61 Spike TV
- 62 Outdoor Channel
- 63 FOX News
- 64 CNN
- 65 msnbc
- 66 CNBC
- 67 Univision
- 68 E!
- 69 Comedy Central
- 70 truTV
- 71 TV Land
- 72 FitTV
- 73 Hallmark Channel
- 74 Bravo
- 75 Food Network
- 76 MTV
- 77 CMT
- 78 VH1
- 79 BET
- 80 Headline News
- 81 Versus
- 82 SOAPnet
- 83 SPEED

- 84 WE tv
- 85 Discovery Kids
- 86 Science Channel
- 87 Galavision
- 88 National Geographic
- 89 RFD TV
- 90 FOX Business News
- 91 Hallmark Movie Channel
- 92 Lifetime Movie Network
- 300 Pay Per View (prices vary)

Preferred (31 channels)*

- 100 Chiller
- 101 Sleuth
- 102 Planet Green
- 103 Investigation Discovery
- 104 Discovery Health
- 105 Military Channel
- 108 ESPNU
- 109 ESPNews
- 110 FOX Soccer Channel
- 111 Oxygen
- 112 Lifetime Real Women
- 113 Turner Classic Movies
- 114 Independent Film Channel
- 115 BBC America
- 116 Game Show Network
- 117 TeenNick
- 118 Nick Jr.
- 120 Nick Too
- 121 NickToons
- 122 bio. (Biography)
- 123 History International
- 124 Military History Channel
- 125 ci (Crime & Investigation)
- 173 G (Gospel Music Channel)
- 174 MTV HITS
- 175 MTV2
- 176 MTV Tr3s
- 177 MTV Jams
- 178 CMT Pure Country
- 179 VH1 Classic
- 180 VH1 Soul

Music Choice (46 channels)*

- 503 Hit List
- 504 Hip-Hop & R&B
- 505 MC MixTape
- 506 Dance/Electronica
- 507 Rap
- 508 Hip-Hop Classics
- 509 Throwback Jamz
- 510 R&B Classics
- 511 R&B Soul
- 512 Gospel
- 513 Reggae
- 514 Classic Rock
- 515 Retro Rock
- 516 Rock
- 517 Metal
- 518 Alternative
- 519 Classic Alternative
- 520 Adult Alternative
- 521 Soft Rock
- 522 Pop Hits
- 523 '90s
- 524 '80s
- 525 '70s
- 526 Solid Gold Oldies

527 Party Favorites
 528 Stage & Screen
 529 Kidz Only!
 530 Toddler Tunes
 531 Today's Country
 532 True Country
 533 Classic Country
 534 Contemporary Christian
 535 Sounds of the Season
 536 Soundscapes
 537 Smooth Jazz
 538 Jazz
 539 Blues
 540 Singers & Swing
 541 Easy Listening
 542 Classical Masterpieces
 543 Light Classical
 544 Musica Urbana
 545 Pop Latino
 546 Tropicales
 547 Mexicana
 548 Romances
Premium Multiplexes (64 channels)*
 200 HBO East
 201 HBO West
 202 HBO2 East
 203 HBO2 West
 204 HBO Signature East
 205 HBO Signature West
 206 HBO Family East
 207 HBO Family West
 208 HBO Comedy East
 209 HBO Comedy West
 210 HBO Zone East
 211 HBO Zone West
 212 HBO Latino East
 213 HBO Latino West
 800 HBO HD
 218 5 STARMAX
 219 OUTERMAX
 220 Cinemax East
 221 Cinemax West
 222 Moremax East
 223 Moremax West
 224 ActionMAX East
 225 ActionMAX West
 226 ThrillerMAX East
 227 ThrillerMAX West
 228 WMAX
 229 @MAX
 820 Cinemax HD
 230 Showtime East
 231 ShoToo East
 232 Showcase
 233 Showtime Extreme
 234 Showtime Beyond
 235 SHO Next
 236 SHO Family
 237 SHO Women
 240 The Movie Channel East
 241 The Movie Channel Xtra
 243 FLIX
 830 Showtime HD
 840 The Movie Channel HD
 250 Starz East
 251 Starz West
 252 Starz Comedy

253 Starz In Black
 254 Starz Kids & Family East
 255 Starz Cinema East
 256 Starz Cinema West
 257 Starz Edge
 260 Encore East
 261 Encore West
 262 Encore WAM East
 264 Encore Westerns East
 265 Encore Westerns West
 266 Encore Mystery East
 267 Encore Mystery West
 268 Encore Action East
 269 Encore Action West
 270 Encore Drama East
 271 Encore Drama West
 272 Encore Love East
 273 Encore Love West
 850 Starz HD
 860 Encore HD
Spanish (10 channels)*
 400 Univision
 401 Galavision
 402 ESPN Deportes
 403 CNN en Espanol
 404 Sorpresa
 405 Discovery en Espanol
 406 Discovery Familia
 407 History Channel en Espanol
 408 Latele Novela
 409 Cine Mexicano
High Definition with Select (61 channels)*
 703 WGN America HD
 704 WHBF (CBS) HD
 706 KWQC (NBC) HD
 707 KLJB (FOX) HD
 708 WQAD (ABC) HD
 712 KIIN (PBS Iowa City) HD
 713 KGCW (CW) HD
 714 WQPT (PBS Moline) HD
 725 The Weather Channel HD
 726 HSN HD
 731 QVC HD
 733 ESPNHD
 734 ESPN2HD
 736 FOX Sports Midwest HD
 737 Comcast SportsNet Chicago HD***
 739 Golf Channel HD
 740 Big Ten Network HD
 741 Disney Channel HD
 742 Nickelodeon HD
 743 ABC Family HD
 744 Cartoon Network HD
 745 Disney XD HD
 746 USA HD
 747 A&E HD
 748 Lifetime HD
 749 Animal Planet HD
 750 Discovery Channel HD
 751 TLC HD
 752 History Channel HD
 753 Travel Channel HD
 754 HGTV HD
 755 AMC HD**
 757 TBS HD
 758 fx HD
 759 TNT HD

760	SyFy HD
761	Spike HD
762	Outdoor Channel HD
763	FOX News HD
764	CNN HD
765	msnbc HD
766	CNBC HD
768	E! HD
769	Comedy Central HD
770	truTV HD
774	Bravo HD
775	Food Network HD
776	MTV HD
777	CMT HD
778	VH1 HD
780	Headline News HD
781	Versus HD
783	SPEED HD
784	WE tv HD**
786	Science Channel HD
788	National Geographic HD
790	FOX Business News HD
791	Hallmark Movie Channel HD
792	Lifetime Movie Network HD
880	HDNet
882	HD Theater
High Definition with Preferred (4 channels)*		
602	Planet Green HD
608	ESPNU HD
609	ESPNews HD
610	FOX Soccer Channel HD**
HD Plus (2 channels)*		
882	HD Theater
881	HDNet Movies
883	Universal HD

** Requires monthly rental of either a digital adapter or a standard or advanced digital box for each television that will receive noted channels. A standard or advanced digital box is required for each television that will receive On Demand or Pay Per View options, as well as Music Choice, Premium, and Spanish package channels. An advanced digital box is required for all televisions that will receive HD and DVR capabilities. A subscription to the premium network suite associated with each HD premium network is required.*

*** Will be added when network becomes available.*

**** Additional programming on Channel 27 when available.*